

PRINTER CONTROLLER

EarlGrey
(Machine Code: C607)

SERVICE MANUAL

PARTS CATALOG

Trademarks

Microsoft®, Windows®, and MS-DOS® are registered trademarks of Microsoft Corporation in the United States and /or other countries.

PostScript® is a registered trademark of Adobe Systems, Incorporated.

PCL® is a registered trademark of Hewlett-Packard Company.

Ethernet® is a registered trademark of Xerox Corporation.

Other product names used herein are for identification purposes only and may be trademarks of their respective companies. We disclaim any and all rights involved with those marks.

Symbols

This manual uses several symbols. The meaning of those symbols are as follows:





	See or Refer to
	Clip ring
	E-ring
	Screw
	Connector

TABLE OF CONTENTS

1. INSTALLATION	1-1
1.1 HARDWARE INSTALLATION	1-1
1.1.1 ACCESSORY CHECK.....	1-1
1.1.2 PRINTER CONTROLLER UNIT INSTALLATION.....	1-2
1.2 PARAMETER SETTINGS	1-5
1.3 UTILITY SOFTWARE SETUP	1-7
1.3.1 SMARTNETMONITOR FOR ADMIN.....	1-7
1.3.2 WEB STATUS MONITOR	1-7
1.4 SETTING UP THE NIB FOR VARIOUS NETWORKS.....	1-8
1.4.1 TCP/IP NETWORKS	1-8
Possible Problems with DHCP Parameter Settings	1-9
1.4.2 NETBEUI NETWORKS	1-10
1.4.3 APPLETTALK (ETHERTALK) NETWORKS.....	1-10
1.4.4 NETWARE NETWORKS	1-11
1.5 INSTALLATION OF OPTIONS	1-12
1.5.1 MEMORY (SDRAM DIMM).....	1-12
2. REPLACEMENT AND ADJUSTMENT.....	2-1
2.1 GENERAL CAUTIONS.....	2-1
2.2 SYMBOLS USED IN TEXT	2-1
2.3 CONTROLLER.....	2-1
2.4 NIB	2-3
2.5 MEMORY (SDRAM DIMM).....	2-4
3. TROUBLESHOOTING	3-1
3.1 ERROR MESSAGE	3-1
3.2 NIB LED INDICATIONS	3-2
4. SERVICE TABLES.....	4-1
4.1 PRECAUTION.....	4-1
4.2 SERVICE PROGRAM MODE OVERVIEW	4-1
4.2.1 HOW TO ENTER THE SP MODE	4-1
Entering Controller SP mode	4-1
4.2.2 SP MODE TABLE.....	4-1
4.2.3 LOAD PROGRAM (SP9-3)	4-5
4.2.4 ERROR RECOVERY.....	4-6
Controller	4-6
PS3/NIB	4-6
5. DETAILED SECTION DESCRIPTIONS	5-1
5.1 OVERVIEW	5-1
5.2 MACHINE LAYOUT.....	5-2

SPECIFICATIONS.....SPEC-1
1. GENERAL SPECIFICATIONS..... SPEC-1
2. SOFTWARE ACCESSORIES SPEC-2
 2.1 PRINTER DRIVERS SPEC-2
 2.2 UTILITY SOFTWARE SPEC-2

PARTS CATALOG AND LIST1

1. INSTALLATION

1.1 HARDWARE INSTALLATION

1.1.1 ACCESSORY CHECK

Check the accessories in the box against the following list.

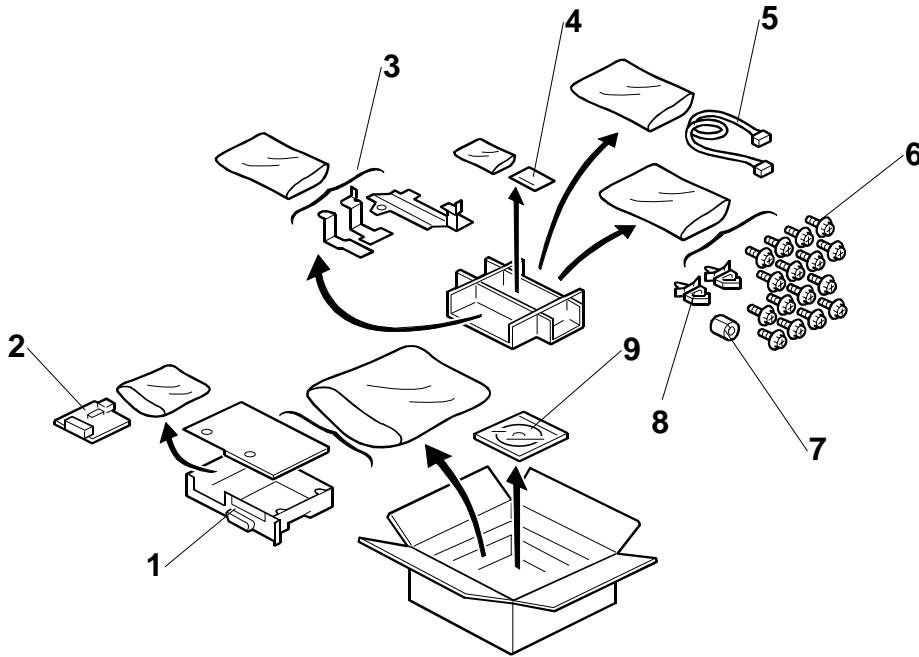

C6071017.WMF

Description	Q'ty
1. Printer Controller Unit *	1
2. Video I/F Board.....	1
3. Bracket	3
4. PostScript Label.....	1
5. Power Cable	1
6. Screw.....	16
7. Core.....	1
8. Cable Clamp.....	2
9. CD-ROM.....	1

*: This circuit operated by +5V circuit.

1.1.2 PRINTER CONTROLLER UNIT INSTALLATION

1. Open the printer controller unit cover [A], and remove the video I/F board [B] from the package. Then attach the printer controller unit cover (⌀ x 4).

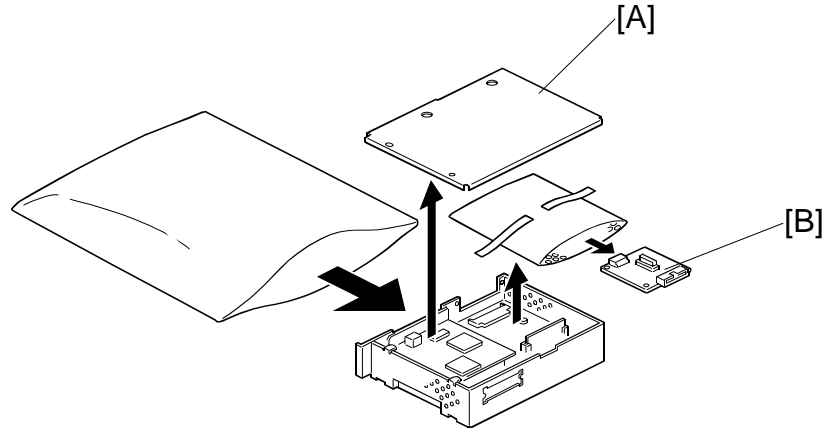

C6071016.WMF

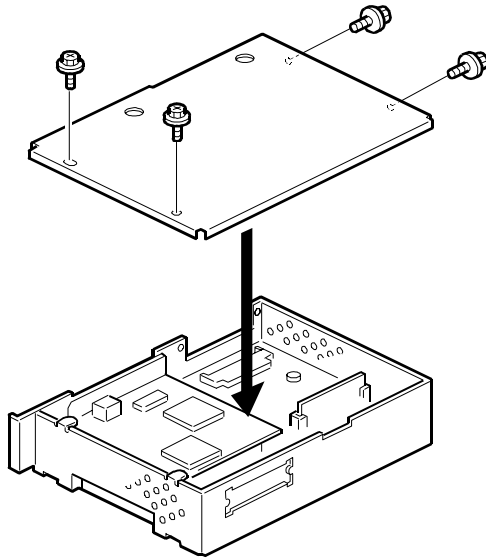

C6071018.WMF

2. Attach three brackets (⌀ x 6).

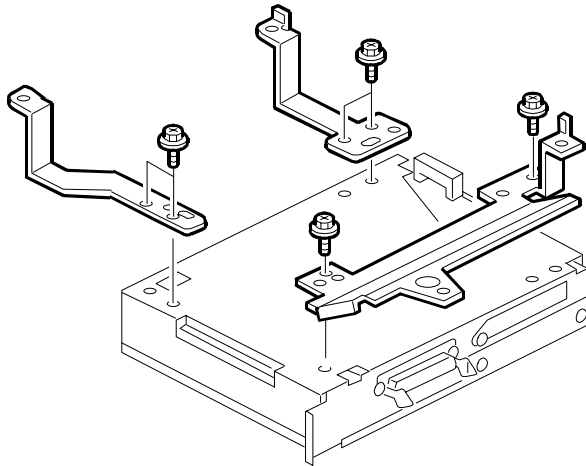

C6071002A.WMF

3. Remove the rear cover [A].

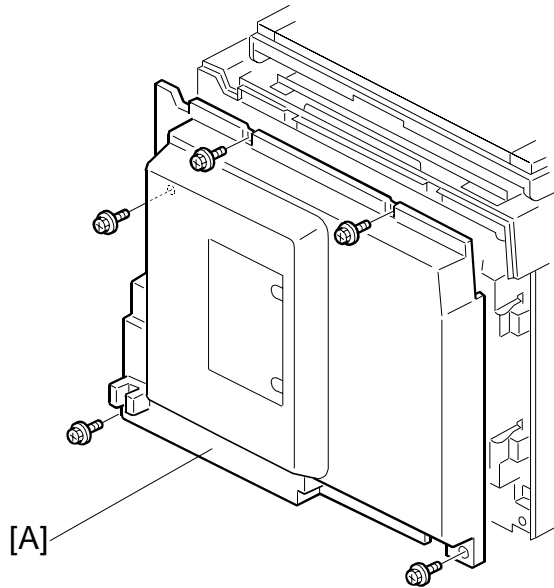

C6071001A.WMF

4. Attach the video I/F board [A], and power cable [B].

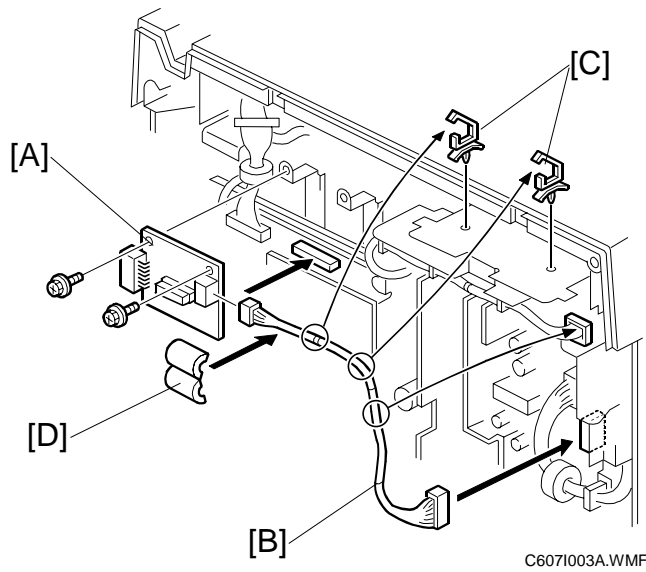

NOTE: 1) Install two cable clamps [C], then clamp the power cable.
2) Attach the core [D] to the power cable.

5. Install the printer controller unit [E] (⌀ x 4).

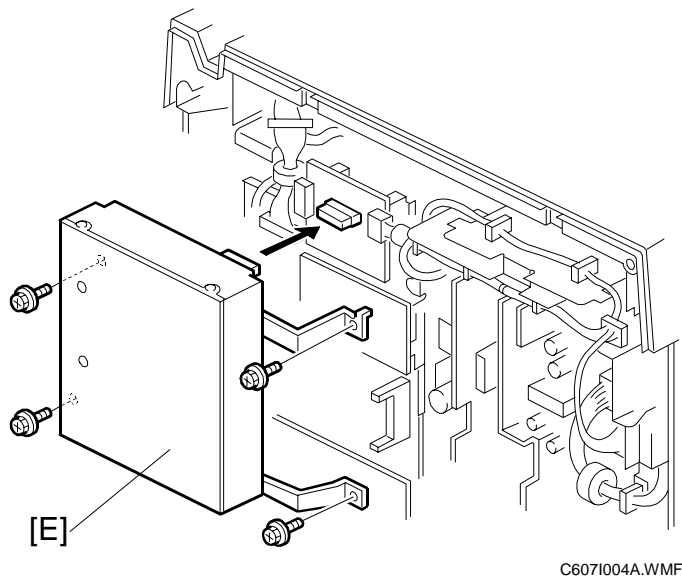

1.2 PARAMETER SETTINGS

After installing the printer controller, change the User Tools settings according to your environment.

(Press the User Tools key, then select Set O/L Paramet's.)

NO.	MENU	SETTINGS	FUNCTION
1	Set auto-O/L def.	*ON OFF	Sets the default setting of the Auto On Line feature.
2	Print Size Def.	*Auto A3☐ B4☐ A4☐ A4☐ B5☐ B5☐ A5☐ A5☐ B6☐ A6☐ Card☐ 11 x 17 ☐ 8 1/2 x 14 ☐ 8 1/2 x 11 ☐ 8 1/2 x 11 ☐ 5 1/2 x 8 1/2 ☐ 5 1/2 x 8 1/2 ☐	
3	List/Test Print	System Print PS Font List	
4	Print PS Errors	ON *OFF	Enables/disables automatic printout of a PS error report if a PS error occurs.
5	IP Address	Set the IP address.	You must turn the power off and then on for the changes to take effect.
6	Ethernet Speed	*Auto 10 Mbps 100 Mbps	You must turn the power off and then on for the changes to take effect.
7	Network	*None RARP+TFTP BOOTP RARP&BOOTP DHCP ARP+PING ARP&RARP ARP&BOOTP ARP&RARP&BOOTP	You must turn the power off and then on for the changes to take effect.

NO.	MENU	SETTINGS	FUNCTION
8	I/O Timeout	15 sec *30 sec 60 sec 180 sec 300 sec	
9	I/O Buffer	16 KB 32 KB 128 KB 256 KB *512 KB	You must turn the power off and then on for the changes to take effect.
10	Menu Reset	Cancel OK	You can reset the factory settings. However, the IP Address, Network, and the Ethernet Speed settings do not change.

*: Factory settings

NOTE: If you need to change other settings in your environment, please change it using the utility software on the CD-ROM.

1.3 UTILITY SOFTWARE SETUP

One of the following utilities is required to monitor and set up the NIB. The utilities are on the Drivers and Utilities CD-ROM that comes with the controller.

1.3.1 SMARTNETMONITOR FOR ADMIN

1. Install SmartNetMonitor for admin from the CD-ROM.
2. Start the NIB setup function from the menu.

1.3.2 WEB STATUS MONITOR

This built-in web server provides an interface to monitor and manage the NIB from a remote host.

1. Assign an IP address to the NIB.
2. Access “http:// <IP address of the NIB> /” from a web browser.

NOTE: 1) Use User Tools at the machine’s operation panel to assign an IP address.
2) Help for Web Status Monitor is on the Drivers and Utilities CD-ROM. After you can access the NIB web server, set up the “Help URL” parameter in the [Network Config.] – [General] page as follows:

< CD-ROM drive letter>: \HELP\WSHLP\EN\index.htm

1.4 SETTING UP THE NIB FOR VARIOUS NETWORKS

This section gives a summary of how to set up the NIB in various network environments.

NOTE: It is not recommended for service technicians to program network and protocol parameters. Ask the customer's network administrator to program and manage these parameters.

1.4.1 TCP/IP NETWORKS

The following parameters are available for TCP/IP network printing.

PARAMETER	DESCRIPTION
Protocol (Default = Enabled)	Disable this if TCP/IP is not used.
IP Address (Default = 11.22.33.44)	IP address of the NIB (required)
Subnet Mask (Default = 0.0.0.0)	Subnet mask for the subnet (required)
Default Gateway (Default = 0.0.0.0)	Default gateway of the subnet. This is required when the NIB accessed from a host in a different subnet.
Access Control Address Access Control Mask	<p>These two parameters are used to allow access to the NIB only to the hosts in the specified subnet.</p> <p>For example, if the Access Control Address is set to "128.1.2.3", access to the NIB is restricted as follows:</p> <ul style="list-style-type: none"> • When Access Control Mask is "255.0.0.0", hosts in the 128.0.0.0 subnet can access the NIB. • When Access Control Mask is "255.255.0.0", hosts in the 128.1.0.0 subnet can access the NIB. • When Access Control Mask is "255.255.255.0", hosts in the 128.1.2.0 subnet can access the NIB. • When Access Control Mask is "255.255.255.255", only the host that has the IP address 128.1.2.3 can access the NIB.
Network Boot	<p>Use "NONE" when an IP address is specified manually (default), or use "DHCP" if the NIB receives an IP address from a DHCP server.</p> <p>All the other settings may not be used, unless the NIB is installed in, for example, a UNIX network.</p> <ul style="list-style-type: none"> • RARP + TFTP • BOOTP • RARP + BOOTP • ARP + PING • ARP & RARP • ARP & BOOTP • ARP & RARP & BOOTP
Frame Type	Ethernet II is always used.

Possible Problems with DHCP Parameter Settings

1. IP address conflicts with an another host

If the IP address conflicts with an another host, the NIB does not show any errors. However, the NIB cannot receive any print jobs, because the IP protocol is disabled automatically at startup.

In this case, the other host in conflict with the NIB must have a manually assigned IP address. Find the host using the PING and ARP commands for example, and assign a suitable address.

2. IP address changes after restarting the machine

The DHCP server may lease a different IP address to the NIB if available IP addresses become in short supply. As a result, the NIB cannot receive any print jobs, because the jobs are sent to the previously assigned IP address.

To solve this problem, reserve an IP address at the DHCP server by allocating an address to the NIB's Ethernet (MAC) Address.

1.4.2 NETBEUI NETWORKS

The following parameters are available for NetBEUI network printing.

In a Microsoft Windows network, the NIB appears like a computer host with a printer connected.

PARAMETER	DESCRIPTION
Protocol (Default = Enabled)	Disable this if NetBEUI is not used.
Workgroup Name (Default = WORKGROUP)	The name of the workgroup to which the NIB belongs in the Microsoft Windows network.
Computer Name	This appears in, for example, the "Network Neighborhood" window to which the printer is connected.
Comment	Comment for the host.
Share Name	Share name of the printer.
Notify Print Completion (Default = Disabled)	Enable this if notification is needed after printing (the controller notifies the NIB, then the NIB notifies the client PC).

1.4.3 APPLE TALK (ETHER TALK) NETWORKS

The following parameters are available for AppleTalk network printing.

PARAMETER	DESCRIPTION
Protocol (Default = Enabled)	Disable this if AppleTalk is not used.
Network No.	The network number of the AppleTalk network to which the NIB is connected is displayed.
Printer Name	Share name of the printer.
Printer Type	"LaserWriter" is always displayed.
Current Zone Name	The default AppleTalk zone name of the network is displayed.
Selected Zone Name	

1.4.4 NETWARE NETWORKS

The following parameters are required for NetWare networks.

PARAMETER	NOVELL 2.X/3.X/4.X/5.X BINDERY NETWORK	NOVELL 4.X/5.X NDS NETWORK
Protocol (Default = Enabled)	Yes	Yes
Operation Mode (Default = Print Server)	Yes (Print Server or Remote Printer)	Yes (Print Server or Remote Printer)
Remote Printer No. (Default = 0)	Yes (See Note 1)	Yes (See Note 1)
Print Server Name	Yes (See Note 2)	Yes (See Note 2)
Print Server Password	Cannot be programmed	Cannot be programmed
File Server Name	Yes	No
NDS Context Name	No	Yes
Preferred NDS Tree	No	Yes (See Note 3)
Print Queue Scan Rate	Cannot be programmed	Cannot be programmed
Frame Type (Default = Auto-Select)	Yes	Yes
Job Timeout (Default = 15 s)	Yes	Yes
Disable Bindery	Cannot be programmed	Cannot be programmed

- NOTE:**
- 1) 'Remote printer number' is necessary only when the "Operation Mode" is "Remote Printer".
 - 2) 'Print server name' is necessary only when the "Operation Mode" is "Print Server". The default name is "RNPxxxxxx" (xxxxxx is the lower 6 digits of the MAC address).
 - 3) The preferred NDS context must be typed in without a starting dot (.).
 - OU=Development.O=Corp [OK]
 - .OU=Development.O=Corp [NG]
 - Development.Corp [OK]
 - .Development.Corp [NG]
 - 4) The following utilities can be used to change the settings.
 - SmartNetMonitor for Admin
 - Web Status Monitor
 - (Telnet)

1.5 INSTALLATION OF OPTIONS

1.5.1 MEMORY (SDRAM DIMM)

1. Turn off the power.
2. Remove the rear cover [A].

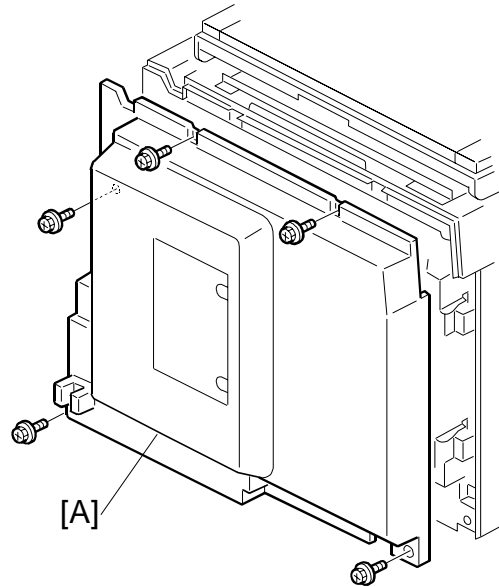

C607I001A.WMF

3. Remove the printer controller unit cover [B] (4 x).

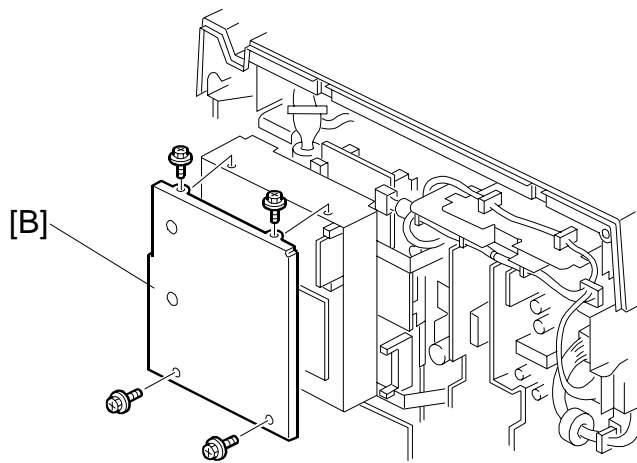

C607I005.WMF

4. After removing the Ethernet board [A], install the additional memory [B].

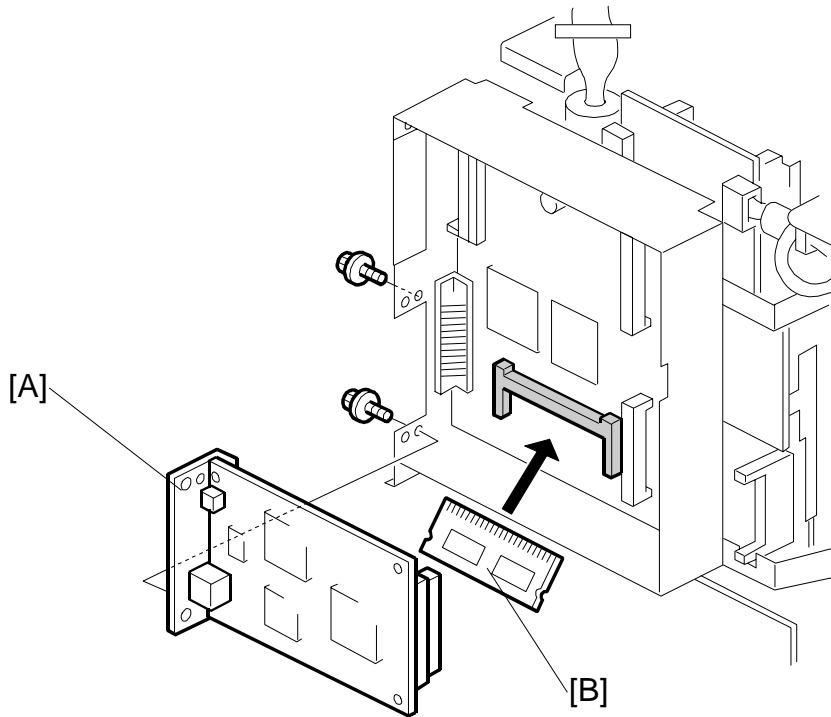

C6071020.WMF

NOTE: Do [User Tools] – [7 Set O/L Paramet's] – [3 List/Test Print] – [System Print] to confirm that the additional memory has been installed successfully.

2. REPLACEMENT AND ADJUSTMENT

2.1 GENERAL CAUTIONS

CAUTION

Before removing any of the controller components, do the following:

1. If the 'data-in' lamp on the operation panel is blinking or lit, wait until the document or report is printed, then turn off the machine.
2. Turn off the main switch and disconnect the power cord, and the cable.

Replacement
Adjustment

2.2 SYMBOLS USED IN TEXT

Screw:  Connector: 

2.3 CONTROLLER

- NOTE:** 1) When replacing the controller board, remove the NVRAM from the defective board, then install the NVRAM on the new board.
- 2) If the controller does not start up after a firmware update, try to download the firmware again. If that does not work, you may need to replace the controller board.

[A]: Rear cover

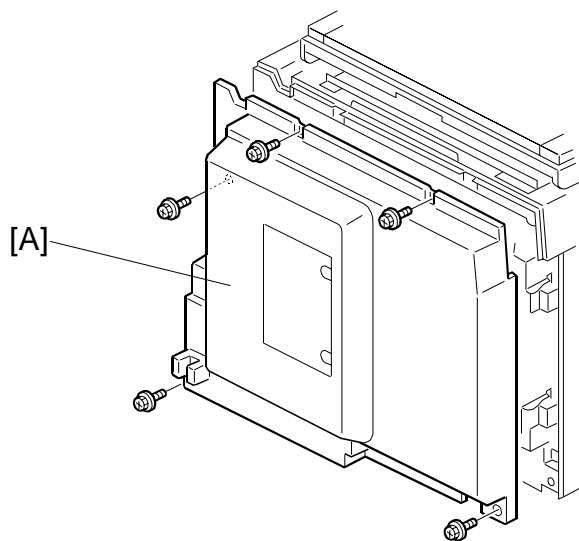

C607D001.WMF

[B]: Controller cover (⚙ x 4)

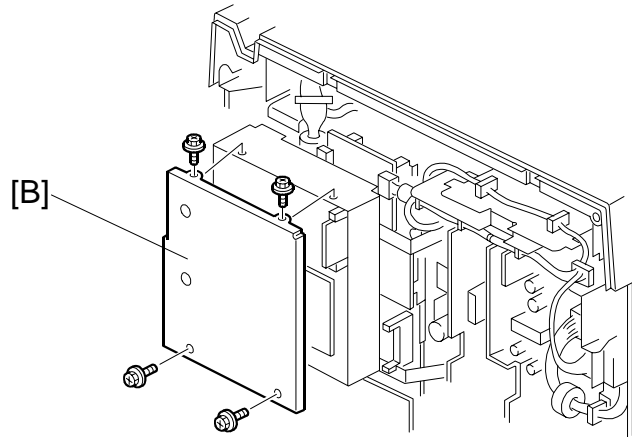

C607D005.WMF

[C]: NIB (⚙ x 2)

[D]: Controller board (⚙ x 6)

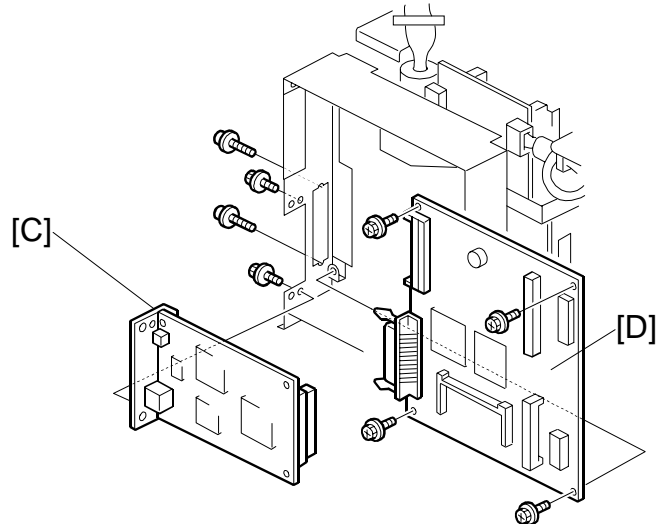

C607D920.WMF

- Remove the optional components and the NVRAM from the controller, then install them on the new controller.
- Print the configuration page ([User Tools] – [7 Set O/L Paramet's] – [3 List/Test Print] – [System Print]). Ensure that all the controller settings are restored.

2.4 NIB

⚠ CAUTION

Before removing any of the controller components, do the following:

1. If the 'data-in' lamp on the operation panel is blinking or lit, wait until a document or report is printed, then turn off the machine.
2. Turn off the main switch and disconnect the power cord, and the cable.

NOTE: Before replacing the NIB, print the configuration page ([User Tools] – [7 Set O/L Paramet's] – [3 List/Test Print] – [System Print]). Then, replace the NIB. Then input the network settings using the User Tools, SmartNetMonitor for Admin, and Web Status Monitor.

1. Print the configuration page using [User Tools] – [7 Set O/L Paramet's] – [3 List/Test Print] – [System Print].
2. Remove the controller cover (☛ 2.3).
3. Replace the NIB (🔧 x 2).
4. Turn on the machine and input the network settings using the utilities.
5. Turn off the machine and turn it back on. Then, print the configuration page ([User Tools] – [7 Set O/L Paramet's] – [3 List/Test Print] – [System Print]). Ensure that all the controller settings are correct.

2.5 MEMORY (SDRAM DIMM)

⚠ CAUTION

Before removing any of the controller components, do the following:

- 1. If the 'data-in' lamp on the operation panel is blinking or lit, wait until a document or report is printed, then turn off the machine.**
- 2. Turn off the main switch and disconnect the power cord, and the cable.**

1. Print the configuration page using [User Tools] – [7 Set O/L Paramet's] – [3 List/Test Print] – [System Print].
2. Remove the controller cover (☛ 2.3).
3. Remove the NIB (🔧 x 2).
4. Replace the SDRAM DIMM.
5. Reinstall the NIB (🔧 x 2).
6. Turn on the machine and print the configuration page ([User Tools] – [7 Set O/L Paramet's] – [3 List/Test Print] – [System Print]). Verify that the total memory has increased.

3. TROUBLESHOOTING

3.1 ERROR MESSAGE

MESSAGE	DESCRIPTION	REQUIRED ACTION
Controller Communication Error	Abnormal communication between the controller and the engine.	Check the connectors and cable connections. Replace the controller board, cable, Video I/F Board, and/or MPU of the engine.
Controller Error	The ROM is faulty.	Replace the controller if this error is frequent.
Font ROM Error	The Font ROM is faulty.	Replace the controller if this error is frequent.
NIC Error	The NIB is abnormal.	Turn off the machine and turn it back on. Replace the NIB if this error is frequent.
NIB Error		
NVRAM Error	An error has occurred in the Memory Unit.	Replace the controller if this error is frequent.
Option RAM Error	There is an error in the SDRAM DIMM (option) module.	Replace the SDRAM DIMM if this error is frequent.
Parallel Interface Error	The parallel interface is abnormal.	Replace the controller if this error is frequent.
CENTRO Error	The parallel interface is abnormal. (After a loop-back test)	Replace the controller if this error is frequent.
ROM Error	The data in the PS DIMM is damaged.	Replace the PS DIMM if this error is frequent.
DIMM ROM Error		
SDRAM Error	There is an error in the on-board SDRAM.	Replace the controller if this error is frequent.
ASIC Error	The controller ASIC is abnormal.	Replace the controller.
Flash ROM Error	The flash ROM is abnormal.	Replace the controller if this error is frequent.
Writing failed	The firmware on the IC card is damaged.	Reprogram the IC card and try again.
Initialization failed	NIB self test failed.	Turn off the machine and turn it back on. Replace the NIB if this error is frequent.
Download mode is disabled	The NIB did not shift into download mode within the specified time.	Replace the NIB if this error is frequent.

3.2 NIB LED INDICATIONS

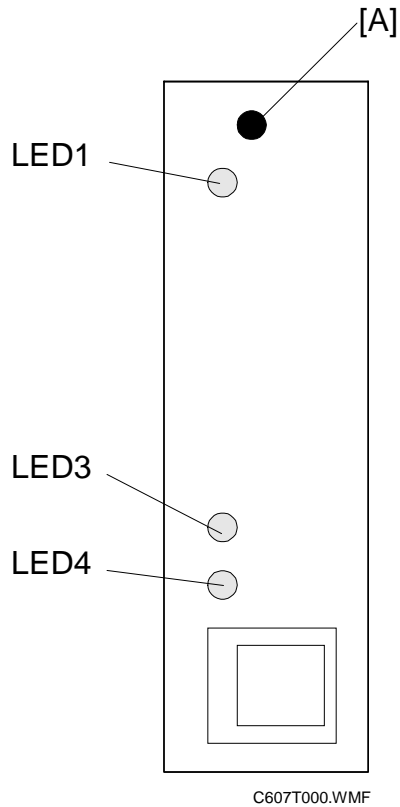

LED	DESCRIPTION	ON	OFF
LED1	Operating status	Ready	Not ready
LED2	Not used	-	-
LED3	Topology	100BaseTX	10BaseT
LED4	Link status	Link success	Link failure

NOTE: The push switch [A] on the NIB is not used.

4. SERVICE TABLES

4.1 PRECAUTION

Do not turn off the machine, or switch the controller off-line, while the data-in LED is blinking or lit. Otherwise, some data that the controller has received for raster image processing may be lost.

Check with the customer before maintenance to avoid such data loss.

4.2 SERVICE PROGRAM MODE OVERVIEW

4.2.1 HOW TO ENTER THE SP MODE

Entering and exiting SP mode is the same as for the digital duplicator, as follows.

NOTE: Before using any of the SP modes, disconnect the parallel and Ethernet cables.

Entering Controller SP mode

 → **1** → **0** → **7** →  (Hold for more than 3 seconds.)

Select "9 Printer Controller". The Printer Controller SP mode main menu appears.

4.2.2 SP MODE TABLE

9 Printer Controller

NO.	DISPLAY	NO.	MENU	DEFAULT	SETTINGS
9-1	Test Mode	1	HEX Dump Print	Disable	Disable/Enable
		2	Service Summary 1 Print	—	—
		3	Service Summary 2 Print	—	—
		4	Parallel Loop-Back Test	—	—
		5	Self-diagnostic Mode	—	—
9-2	Clear Mode	1	Config data	—	—
		2	Controller NVRAM	—	—
		3	NIB NVRAM	—	—
9-3	Load Program	1	Load Program-System	—	—
		2	Load Program-NIB	—	—

SP9-1-1 (HEX Dump Print)

This prints Hex Dump data using the controller.

NOTE: The Hex Dump Print is not used.

SP9-1-2 to -3 (Service Summary 1 Print, Service Summary 2 Print)

This prints a summary of all the controller settings.

1. Enter the Printer Controller SP mode, and select "Test Mode".
2. Select "Service Summary 1 Print" or "Service Summary 2 Print", then press the # key.

- **Model Number / System Version / Unit Number**
Lists the machine's Plug&Play name, controller firmware version, and the controller part number.
- **Program List**
Lists the firmware module version.
- **Bit Switch**
Lists the current bit switch settings. Designer use only.
- **Counter**
Lists all the counters in the controller.
NOTE: Some counters listed in the report, such as the "Duplex Printed Page Count" are not actually used.
- **Exception Information**
Lists CPU exception error information. Designer use only.
- **System Logging / System Logging 2**
Lists internal log data. Designer use only.
- **Option**
Lists all the installed option components.

SP9-1-4 (Parallel Loop-Back Test)

This tests the standard IEEE 1284 parallel interface using a loop-back connector. The loop-back connector (P/#: G0219350) is required for this test.

NOTE: Do not use the loop-back connector with P/#: G0109350. This loop-back connector causes a timeout error.

1. Turn off the machine and attach the loop-back connector to the Centronics parallel interface.
2. Turn on the machine.
3. Enter the Printer Controller SP mode, and select "Test Mode".
4. Select "Parallel Loop-Back Test", then press the # key.
5. Check the error message. (☛ 3.1)

SP9-1-5 (Self-diagnostic Mode)

The controller tests the following devices. If an error is detected, an error code appears on the operation panel. (☛ 3.1)

- Resident and optional SDRAM
- ASIC
- NVRAM
- Font ROM
- Flash ROM
- NIB

⚠ CAUTION

Do not turn off the machine while this test is running.

SP9-2-1 (Config data)

This initializes the following settings in the controller NVRAM.

- Controller diagnostics error log
- The network parameter settings in the User Tools except for "5. IP Address", "6. Ethernet Speed", and "7. Network".

SP9-2-2 (Controller NVRAM)

This initializes all the data in the controller NVRAM, but does not initialize the NIB settings.

SP9-2-3 (NIB NVRAM)

This initializes all the data in the NIB NVRAM.

SP9-3-1 (Load Program-System)

This upgrades the system data (firmware) for the controller. (☛ 4.2.3)

SP9-3-2 (Load Program-NIB)

This upgrades the network interface board. (☛ 4.2.3)

4.2.3 LOAD PROGRAM (SP9-3)

This procedure is for upgrading the system firmware for the controller, the network interface board.

CAUTION

Do not turn off the machine while downloading the firmware.

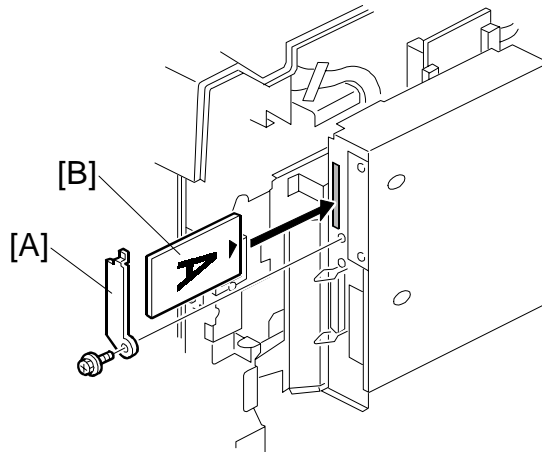

C607R009.WMF

Service
Tables

1. Before downloading new firmware, print the configuration page ([User Tools] – [7 Set O/L Paramet's] – [3 List/Test Print] – [System Print]), then check the current version.
2. Prepare an IC card that contains the required firmware.
3. Turn off the machine and remove the rear cover.
4. Remove the cover [A] (⌀ x 1), then install the card [B] in the IC card slot on the controller.
NOTE: The “A” side of the IC card must face towards the rear of the machine.
5. Turn on the machine and enter the SP number.
6. Press the # key, then downloading starts automatically.
“Executing” blinks on the display during the download, which take about 3 minutes.
When the download is finished, the display changes to “Completed”.
7. After the firmware download has finished, turn off the machine, and remove the card. Then, re-install the cover [A] and rear cover.
8. Turn on the machine, and print the configuration page ([User Tools] – [7 Set O/L Paramet's] – [3 List/Test Print] – [System Print]) to confirm that the new firmware version has been installed.

4.2.4 ERROR RECOVERY

Controller

If the controller does not start up after a failed firmware download, use the following procedure. This procedure will force the controller to boot from the IC card.

1. Prepare an IC card with the required controller firmware version on it.
2. Turn off the machine and remove the rear cover and controller cover (ⓘ x 4).
3. Change the DIP-SW-1 setting to "ON".
4. Install the card in the IC slot on the controller.
NOTE: The "A" side of the IC card must face towards the rear of the machine.
5. Turn on the machine.
6. Wait until the LED's between the IC card slot and the parallel interface are both lit (this may take 1 to 2 minutes).
7. Turn off the machine, remove the card, and reset DIP-SW-1 to "OFF". Then, attach the controller cover.
NOTE: The default settings of the DIP switches are all "OFF".
8. Turn on the machine, and print the configuration page.

PS3/NIB

If a download attempt failed, try downloading the new firmware again.

5. DETAILED SECTION DESCRIPTIONS

5.1 OVERVIEW

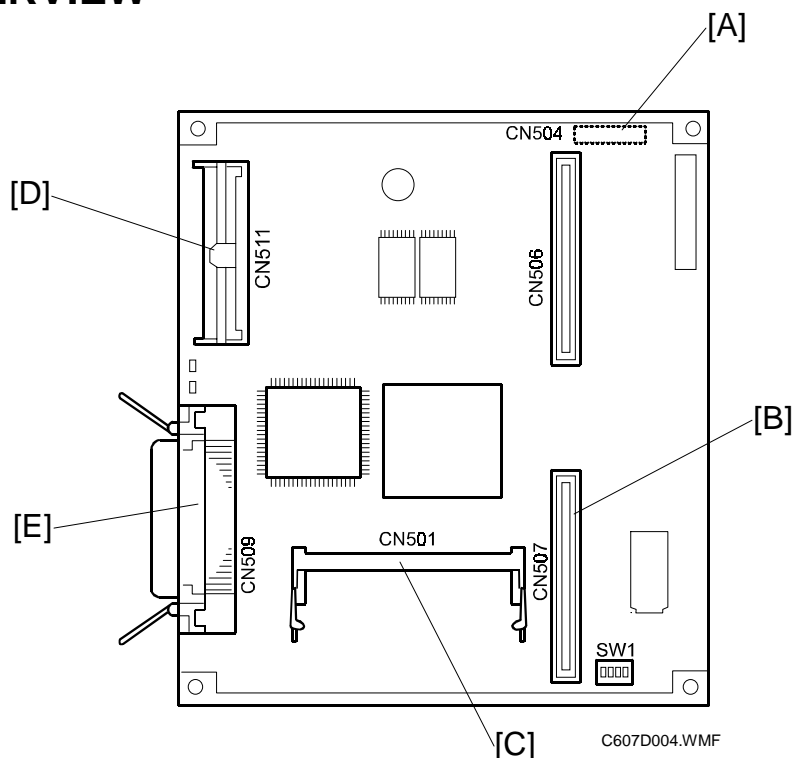

The controller board contains a CPU (QED RM5261) and an ASIC. The ASIC controls the main memory (SDRAM), ROM interface, IEEE1284 parallel interface, option bus interface for the NIB, and an IC card interface for upgrading firmware.

There is one optional memory socket that can have a 32 MB, 64 MB, or 128 MB SDRAM DIMM module to increase RAM capacity and enable RAM collation.

The IC card interface allows the firmware for the controller, PostScript, and NIB to be upgraded.

Detailed Descriptions

REF.	CONNECTOR			DESCRIPTION
	NAME	NO.	CONFIGURATION	
A	Engine Interface	CN504	Halfpitch 30 pin	To video I/F
B	OPTBUS I/F	CN507	Halfpitch 80 pin	For connecting the NIB
C	SDRAM DIMM I/F	CN501	144 pin SODIMM	For connecting the SDRAM (option)
D	IC-Card I/F	CN511	JEIDA v4.0 68pin	For connecting the IC card for firmware upgrades
E	IEEE1284 I/F	CN509	IEEE1284 parallel interface	To the host computer

5.2 MACHINE LAYOUT

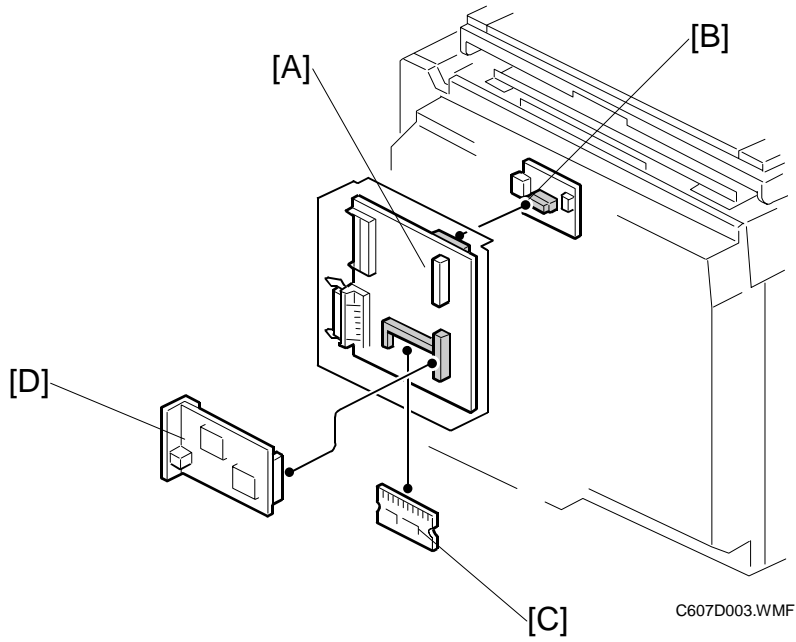

REF.	COMPONENT
A	Printer Controller Board
B	Video Interface Board
C	SDRAM Module (option)
D	Network Interface Board

SPECIFICATIONS

1. GENERAL SPECIFICATIONS

CONTROLLER TYPE	EMBEDDED
Connectable Machines	C244, C239 Models
Printer Languages	PostScript 3 PCL 5e
Print Resolution	PCL5e – 600 dpi PostScript 3 – 400/600 dpi
Memory (SDRAM)	32 MB (standard) 160 MB (maximum) NOTE: There is 1 slot for a 32, 64 or 128 MB SDRAM DIMM.
Resident Fonts	PCL: 45 fonts (35 Intellifonts, 10 TrueType fonts and 1 bitmap font) PS3: 136 fonts
Host Interfaces	IEEE1284/ECP parallel interface Ethernet 10BaseT/100BaseTX network interface
Other Interfaces	SDRAM DIMM interface (for optional memory) IC Card interface (for upgrading firmware)

2. SOFTWARE ACCESSORIES

The printer drivers and utility software are provided on one CD-ROM.

2.1 PRINTER DRIVERS

PRINTER LANGUAGE	WINDOWS 95/98/ME	WINDOWS NT4.0	WINDOWS 2000	MACINTOSH
PCL5e	Yes	Yes	Yes	No
PS3	Yes	Yes	Yes	Yes

- NOTE:** 1) The printer drivers for windows NT 4.0 are only for the Intel x86 platform. There is no Windows NT 4.0 printer driver for the PowerPC, Alpha, or MIPS platforms.
- 2) The PS3 drivers are all genuine AdobePS drivers, except for Windows 2000, which uses Microsoft PS. A PPD file for each operating system is provided with the driver.
- 3) The PS3 drivers for Macintosh support Mac OS 7.6.1 or later versions.

2.2 UTILITY SOFTWARE

SOFTWARE	DESCRIPTION
SmartNetMonitor for Admin (Win 95/98/ME, NT4, 2000)	A printer management utility for network administrators. NIB setup utilities are also available.
SmartNetMonitor for Client (Win 95/98/ME, NT4, 2000)	A printer management utility for client users. Peer-to-peer printing utility and parallel/recovery printing functions are included.

PARTS CATALOG AND LIST

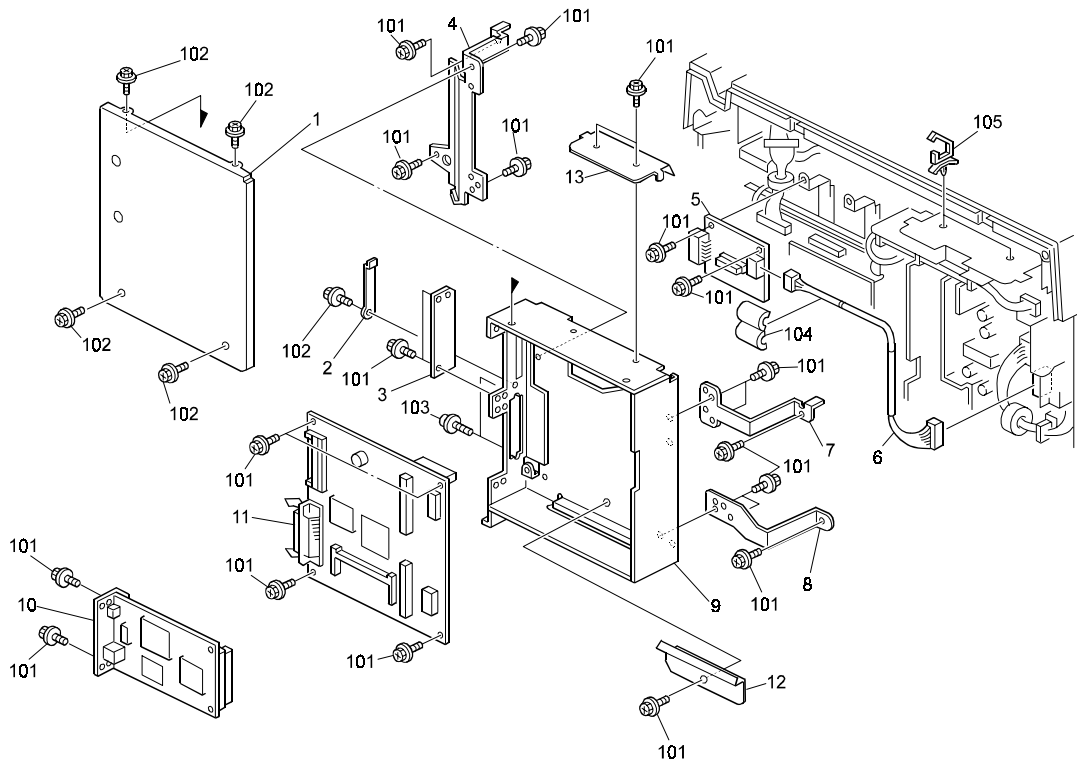

C607R501.WMF

Index No.	Part No.	Description	Q'ty Per Assembly
1	C613 5645	Shading Plate	1
2	G038 5826	IC Card Cover	1
3	G038 5813	Connector Cover	1
4	C607 5651	Left Stand	1
5	C607 5150	Video I/F Board	1
6	C607 5201	Controller Power Cable	1
7	C607 5652	Upper Right Stand	1
8	C607 5653	Lower Right Stand	1
9	C607 5631	Controller Box	1
10	G678 5856	PCB C4000-R Assy	1
11	C607 5130	Controller Board	1
12	C607 5672	Ground Plate – 2	1
13	C607 5671	Ground Plate – 1	1
101	0451 3006B	Tapping Screw – M3x6	
102	0451 3006H	Tapping Screw – 3x6	
103	0951 3010Z	Philips Screw With Flat Washer – M3	
104	1607 1139	Ferrite Core	
105	1105 0310	Wire Clamp	
	C607 8608	Operating Instructions – EU	
	C607 8607	Operating Instructions – NA	
	C607 6048	Driver CD-ROM – EU	
	C607 6042	Driver CD-ROM – NA	

Parts
Catalog
& List